

173 - AUDIO/VIDEO

SONORA is pleased to introduce the 173PL40 and 173PL49. Both are beautifully crafted wood and glass video stands that are reinforced with a metal structure. A precision curved wood front gives the 173 series an outstanding and popular appeal. This series is available in an elegant medium brown (MB) or gloss black finish (N). To make things even better, an optional 173PE-N plasma tilt and swivel support bracket is available and easily attaches at the rear to hold a flat panel TV weighing up to 110 lbs.

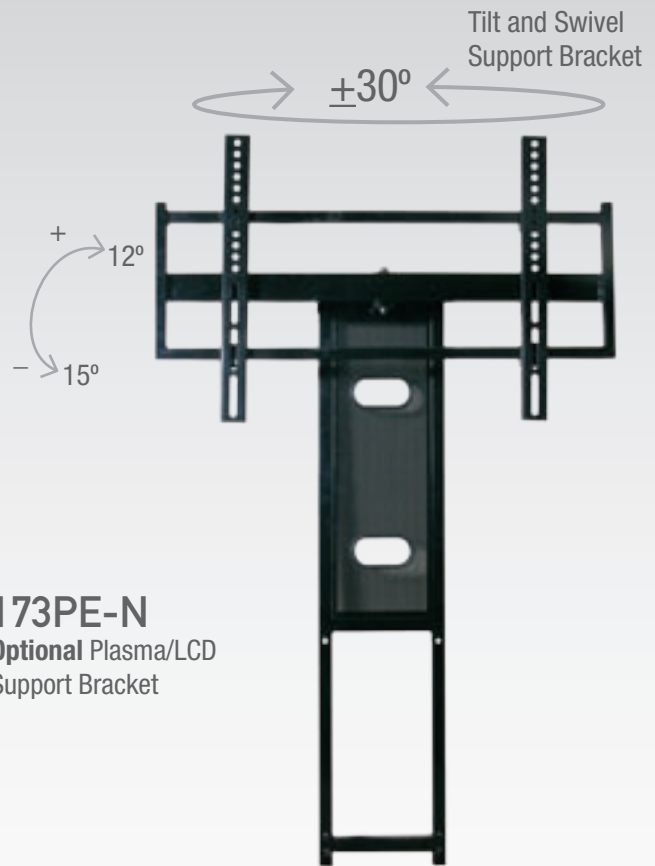

173PE-N
Optional Plasma/LCD
Support Bracket

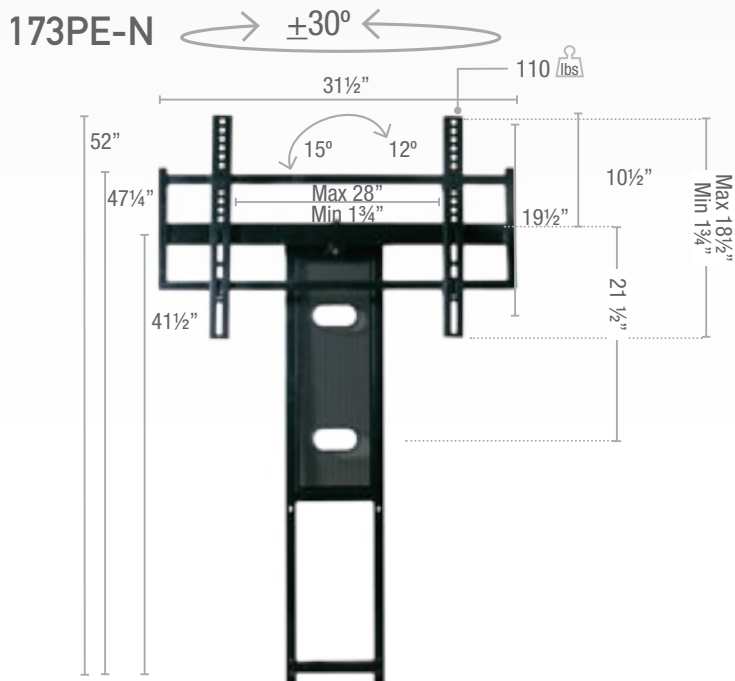

COLOUR

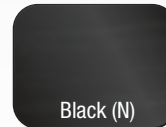

Can also be used with models S51 / S52 series,
found on page 42 / 43.